



Neff  
B45M52N3GB  
Electric built-in oven  
  
Predecessor:  
  
Successor:

EAN code:  
4242004157595  
  
sales programme:

**B45M52N3GB**  
**Electric built-in oven**  
**Stainless steel**

- Multifunction oven with 8 cooking functions CircoTherm 50 °C - 200 °C, Top/ bottom heat 50°C - 275 °C, Bottom heat, Full surface grill, Half width grill, CircoRoasting 50°C - 250° C, Defrost setting, Pizza setting 50°C - 275°C
- Large capacity oven with shelf supports
- Round lamp
- Revolution handle
- SlideAway door
- Grey Enamel
- CeramiClean side, back and roof liners
- Automatic cleaning-mode for self clean
- Full glass inner door - safer touch door
- Cooling fan
- Bedienblende Stainless steel with finished faceted glass
- Retractable controls
- Electronic control: mechanical
- Rapid heating-up
- Electronic clock
- Operating light
- Energy efficiency rating (acc. EU Nr. 65/2014):  
Energy consumption per cycle in conventional mode: 0.96 kWh  
Energy consumption per cycle in fan-forced convection mode: 0.84 kWh  
Number of cavities: 1  
Heat source: electrical  
Cavity volume: 66 l

**Included accessories**

2 x baking and roasting shelf cranked,  
1 x universal pan, 1 x insert grid

**Optional accessories**

- N8642X3 System steam cooker
- Z1240X2 ACCESSORIES COOKER/ OVEN
- Z1262X0 glasspan
- Z1272X0 ACCESSORIES COOKER/ OVEN
- Z1343X0 Accessory
- Z1512X0 Accessory
- Z1701X2 ACCESSORIES COOKER/ OVEN
- Z1742X2 ACCESSORIES COOKER/ OVEN
- Z1755X2 ACCESSORIES COOKER/ OVEN

**Alternative colors available**

**Technical Data**

**Characteristics**

Color / Material Front : Stainless steel  
Built-in / Free-standing : Built-in  
Integrated Cleaning system : Catalytic all sides  
Required niche size for installation (HxWxD) : 590-593 x 560-570 x 550  
Dimensions of the product (mm) : 595 x 595 x 550  
Control Panel Material : stainless steel + glass insert  
Door Material : Glass  
Net weight (kg) : 38.0  
Usable volume of cavity (l) : 66  
Temperature control : mechanical  
Number of interior lights : 1  
Approval certificates : CE, VDE  
Interior Lights - cavity 1 : 1  
Pull-out system : Accessory  
Clock function : Alarm, Off, On  
Included accessories cavity 1 : 2 x baking and roasting shelf cranked, 1 x universal pan, 1 x insert grid  
Broil Element Wattages cavity 1 (W) : 2800

**Consumption and connection features**

Energy consumption conventional (kWh) - cavity 1 : 0.95  
Energy consumption forced air convection (kWh) - cavity 1 : 0.79  
Electrical connection rating (W) : 3680  
Current (A) : 16  
Voltage (V) : 240  
Frequency (Hz) : 50  
Plug type : no plug  
Color / Material Front : Stainless steel  
Energy input : Electric  
Approval certificates : CE, VDE  
Dimensions of the packed product (in) : 26.57 x 25.98 x 27.16  
Net weight (lbs) : 84  
Gross weight (lbs) : 91  
Required niche size for installation (HxWxD) : 590-593 x 560-570 x 550  
Dimensions of the product (mm) : 595 x 595 x 550  
Net weight (kg) : 38.0  
Gross weight (kg) : 41.0

**B45M52N3GB**  
Electric built-in oven  
Stainless steel

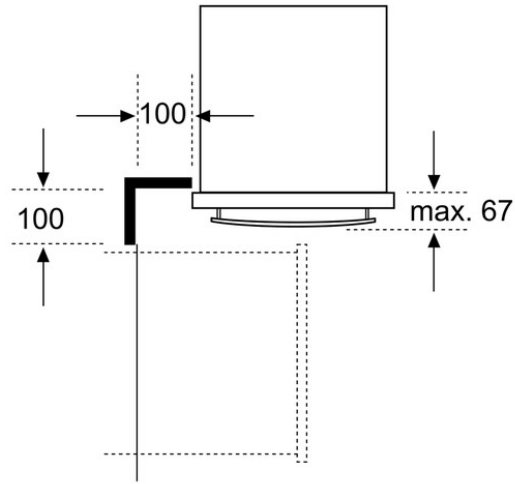

Measurements in mm

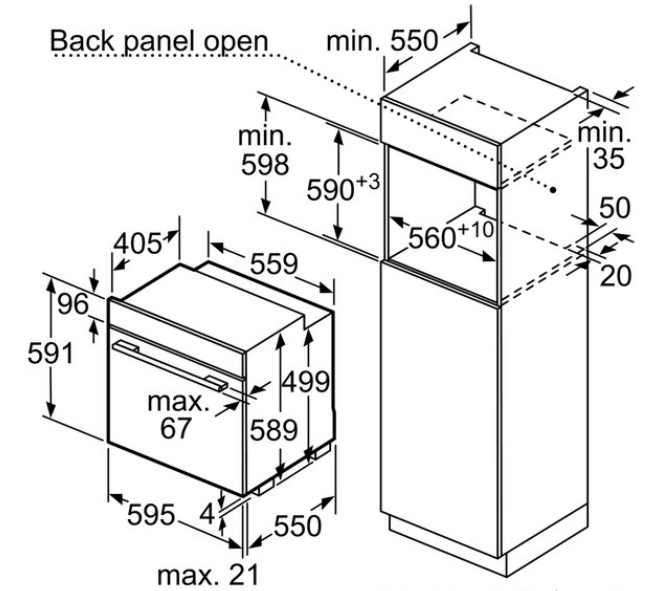

measurements in mm

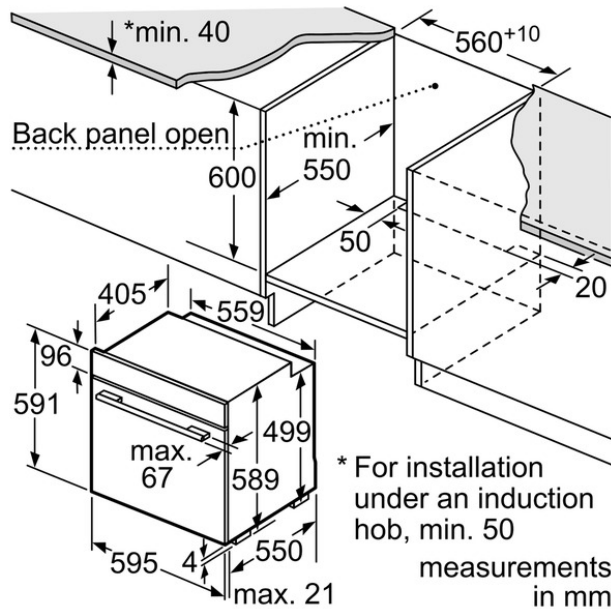

measurements in mm